

PUP. Front wall

DWG NO. 10AH0466 REV. B SHEET 1 OF 2

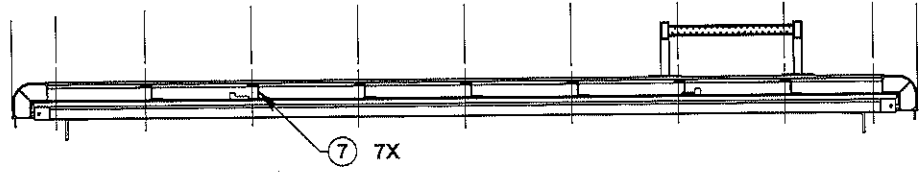
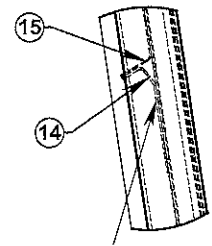
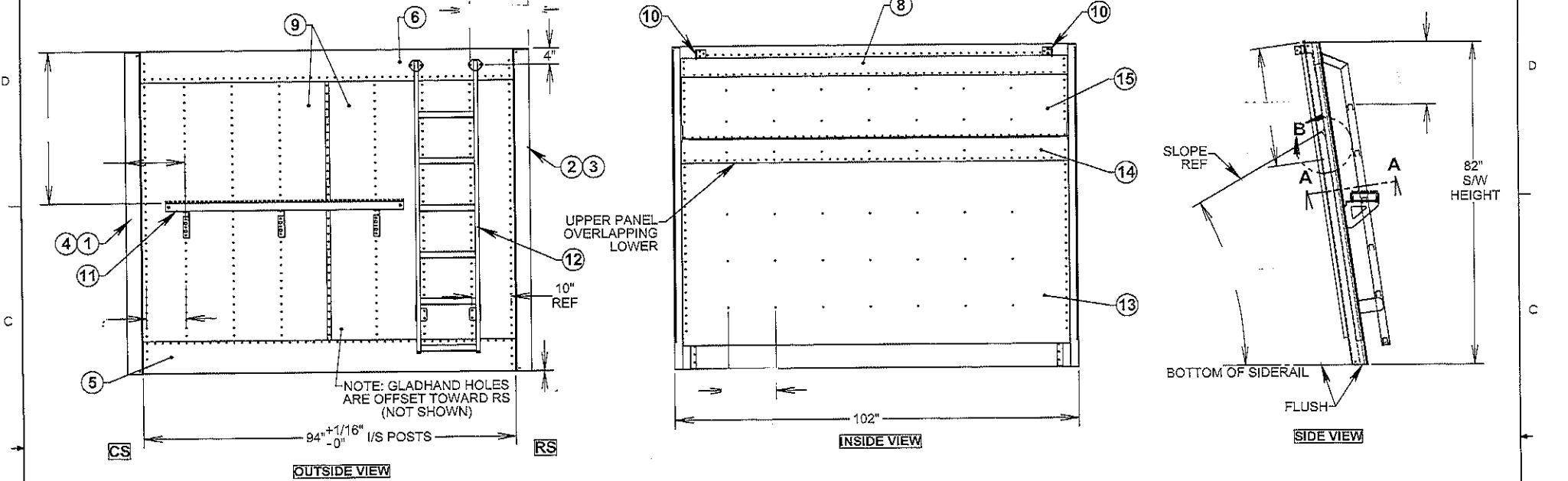

MATERIAL NO.	MATERIAL DESC.	Mass = 248.928lbs
DRWN KH	24-Mar-17	DWG FILE: \\112503\10A\10AH0466.dwg
UNLESS OTHERWISE SPECIFIED		
DIMENSIONS ARE IN INCHES		
TOLERANCES ARE:		
FRACTIONS DECIMALS ANGLES		
1/16 0.001 30.0 1/16		
XXX.0000		
DRAWING TITLE		
FRONT WALL ASSY, AHV PUP, 82", SS		

REV.	ECO NO.	BY	DATE	DESCRIPTION	SCALE	SHEET	DWG. NO.	REV.
	112503	KH	13-Apr-17	ADD 'SS' TO DWG DESCRIPTION	1:24	B	10AH0466	B

PUP Front wall

DWG. NO. 10AH0466 REV. B SHEET 2 of 2

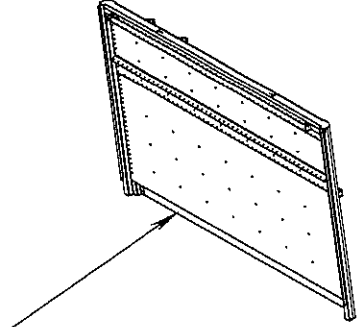

10AH0466W
FRONT WALL ASSY, AHV PUP, 82", WHITE, SS
REV B

ITEM NO.	QTY.	PART NO.	DESCRIPTION
1	1	10AA1817	CORNER POST, 82, FRONT, CS
2	1	10AA1818	CORNER POST, 82, FRONT, RS
3	1	10AA1819	COVER, SS 82" RS
4	1	10AA1820	COVER, SS 82" CS
5	1	10AA1639	PLATE, COVER, TRAIN
6	1	10AA1654	RAIL, TOP, AHV
7	7	10AA38201	Z-POST, STIFFENER, SIDEWALL
8	1	10AA1725	ANGLE, END WALL
9	2	10AB82C81	SKIN, EXTERIOR, ENDWALL, 82" - WHITE
10	2	10AC1012	ANGLE, CORNER
11	1	50AG0413	CATWALK ASY AHV2 60"
12	1	50AG0925	LADDER ASY, 82H B-TRAIN
13	1	10AC1013	PANEL, BOT, LEAD, FRONT WALL I/S
14	1	10AM0803	SLOPE END WALL MNT LOWER - PULL FRONT
15	1	10AM0805	SLOPE END WALL MNT UPPER - PULL FRONT 82
16	1	40AP0009	ENDWALL FASTENER ASSY

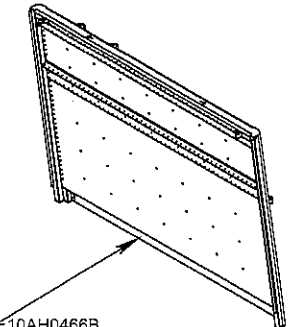

10AH0466B
FRONT WALL ASSY, AHV PUP, 82", BLACK, SS
REV B

ITEM NO.	QTY.	PART NO.	DESCRIPTION
1	1	10AA1817	CORNER POST, 82, FRONT, CS
2	1	10AA1818	CORNER POST, 82, FRONT, RS
3	1	10AA1819	COVER, SS 82" RS
4	1	10AA1820	COVER, SS 82" CS
5	1	10AA1639	PLATE, COVER, TRAIN
6	1	10AA1654	RAIL, TOP, AHV
7	7	10AA38201	Z-POST, STIFFENER, SIDEWALL
8	1	10AA1725	ANGLE, END WALL
9	2	10AB82C82	SKIN, EXTERIOR, ENDWALL, 82" - BLACK
10	2	10AC1012	ANGLE, CORNER
11	1	50AG0413	CATWALK ASY AHV2 60"
12	1	50AG0925	LADDER ASY, 82H B-TRAIN
13	1	10AC1013	PANEL, BOT, LEAD, FRONT WALL I/S
14	1	10AM0803	SLOPE END WALL MNT LOWER - PULL FRONT
15	1	10AM0805	SLOPE END WALL MNT UPPER - PULL FRONT 82
16	1	40AP0009	ENDWALL FASTENER ASSY

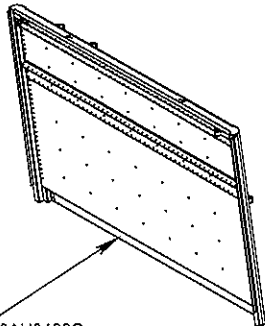

10AH0466G
FRONT WALL ASSY, AHV PUP, 82", GREY, SS
REV B

ITEM NO.	QTY.	PART NO.	DESCRIPTION
1	1	10AA1817	CORNER POST, 82, FRONT, CS
2	1	10AA1818	CORNER POST, 82, FRONT, RS
3	1	10AA1819	COVER, SS 82" RS
4	1	10AA1820	COVER, SS 82" CS
5	1	10AA1639	PLATE, COVER, TRAIN
6	1	10AA1654	RAIL, TOP, AHV
7	7	10AA38201	Z-POST, STIFFENER, SIDEWALL
8	1	10AA1725	ANGLE, END WALL
9	2	10AB82C83	SKIN, EXTERIOR, ENDWALL, 82" - GREY
10	2	10AC1012	ANGLE, CORNER
11	1	50AG0413	CATWALK ASY AHV2 60"
12	1	50AG0925	LADDER ASY, 82H B-TRAIN
13	1	10AC1013	PANEL, BOT, LEAD, FRONT WALL I/S
14	1	10AM0803	SLOPE END WALL MNT LOWER - PULL FRONT
15	1	10AM0805	SLOPE END WALL MNT UPPER - PULL FRONT 82
16	1	40AP0009	ENDWALL FASTENER ASSY

Mass = 248.928lbs

MATERIAL NO.	MATERIAL DISCR.
DRAWN KH 24-MAR-17	DATE FILED WALKER 24-MAR-17
UNLESS OTHERWISE SPECIFIED DIMENSIONS ARE IN INCHES. TOLERANCES ARE FRACTIONS DECIMALS ANGLES ± 1/16 ± .005 ± .01 ± .1	
LODEWORKING INC.	
BOX 1146 WINKLER, MANITOBA, CANADA R6W 4R2	

FRONT WALL ASSY, AHV PUP, 82", SS

REV. 112503	CH	13-APR-17	ADD SS TO DWG DESCRIPTION	SCALE 1:40	SIZE B	SHEET 2 of 2	DWG. NO. 10AH0466	REV. B
-------------	----	-----------	---------------------------	------------	--------	--------------	-------------------	--------